

# CFT

COMPOSITE FAN TECHNOLOGY

# SERVICE MANUAL

## MODEL CVC

*Fiberglass Upblast Centrifugal Fan*

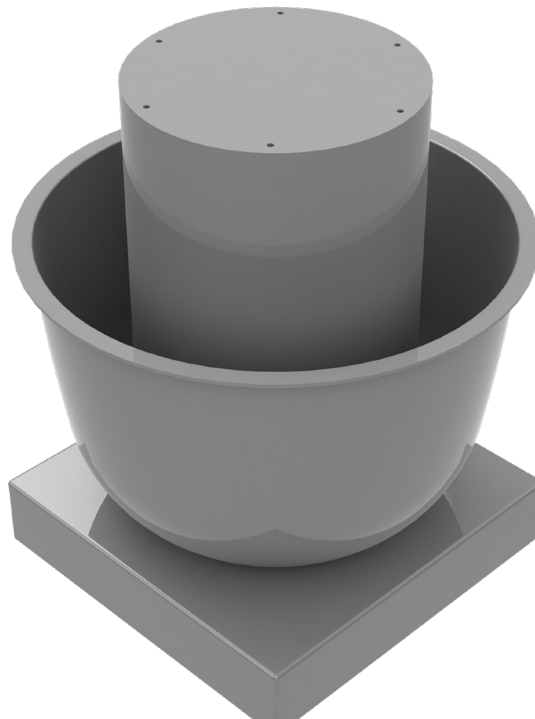

# CFT<sup>®</sup>

A Division of VPC Fiberglass™ 2020

VPCFIBERGLASS.COM

P: 585.735.9668  
F: 585.735.9965

ADMINISTRATIVE OFFICES

2410 North Forest Road, Suite 301  
Getzville, NY 14068

LOCKPORT MANUFACTURING

75 Michigan Street, Suite 2  
Lockport, NY 14094



MEDINA MANUFACTURING

10478 Ridge Road  
Medina, NY 14103

## BEFORE YOU BEGIN

This manual is prepared to assist you with the installation, operation, and maintenance of your Composite Fan Technology fiberglass fan. It is imperative that an experienced mechanic familiar with rotating machinery install and start-up this equipment. Composite Fan Technology supports its equipment with the warranty policy attached at the end of this manual. Please read the warranty section thoroughly before adjusting or repairing any fan components. Arrangements for service work are made through our office in Lockport, NY.

### CAUTION

THIS MACHINE HAS MOVING PARTS THAT CAN CAUSE SERIOUS BODILY INJURY, BEFORE OPERATING OR PERFORMING MAINTENANCE, THE FOLLOWING PRECAUTIONS MUST BE TAKEN.

- 1.) MAKE SURE ALL MOVING PARTS ARE SHIELDED FROM PERSONNEL AND FALLING OBJECTS.
- 2.) READ THE INSTALLATION AND MAINTENANCE INSTRUCTIONS AS WELL AS THE RECOMMENDED SAFETY PRACTICES MANUAL FURNISHED WITH THIS UNIT.
- 3.) DO NOT OPERATE AT SPEEDS OR TEMPERATURES HIGHER THAN PUBLISHED FOR THE SPECIFIC OPERATING CONDITIONS.

### SAFETY

Improperly installed or operated fans can be a danger to both people and property. Fans should always be installed by trained and experienced personnel. Installations must meet all pertinent federal, state, and local codes and requirements of OSHA. All personnel should read AMCA Publication 410, recommended safety practices for Air Moving Devices.

### ELECTRICAL DISCONNECTS

ALL MOTOR DRIVEN FANS MUST BE CONNECTED TO A DISCONNECT SWITCH SO THE MONITOR CAN BE PREVIOUSLY ISOLATED FROM THE POWER SOURCE. MAINTENANCE PERSONNEL MUST CONTROL POWER TO THE UNIT TO AVOID STARTING OF EQUIPMENT DURING MAINTENANCE OR REPAIR.

# CFT<sup>®</sup>

A Division of VPC Fiberglass™ 2020



VPCFIBERGLASS.COM

ADMINISTRATIVE OFFICES

LOCKPORT MANUFACTURING

MEDINA MANUFACTURING

P: 585.735.9668  
F: 585.735.9965

2410 North Forest Road, Suite 301  
Getzville, NY 14068

75 Michigan Street, Suite 2  
Lockport, NY 14094

10478 Ridge Road  
Medina, NY 14103

# INSTALLATION, OPERATION & MAINTENANCE INSTRUCTIONS

## **RECEIVING AND INSPECTION:**

Unless specifically agreed otherwise, shipments are made F.O.B. shipping point. The equipment becomes the property and responsibility of the buyer at the point of shipment. All equipment is inspected and prepared for shipment in accordance with the requirements of the commercial carrier and/or any special consideration required by the nature of the product. Rough handling or the forces encountered during shipping may cause damage to the unit(s). The buyer should carefully inspect the shipment before accepting delivery from the carrier. Shipping damage and claims are the responsibility of the buyer for shipments made F.O.B shipping point. All damages or shortages discovered at the time of delivery must be noted on the carrier's freight BOL and reported to the carrier immediately. The carrier should inspect the damage with the receiver and a concealed damage report filed.

## **HANDLING AND STORAGE**

Handle your equipment with care. Most shipments can be offloaded and handled with standard fork trucks. Fans should be lifted by their bases using straps and spreader bar where necessary. Do not lift fan by rotor, shaft, motor, or motor lifting lug.

For long term storage, the following should be done:

1. Add additional grease to bearings to fill any voids and prevent condensation buildup.
2. Remove drive belts and store in a dry protected area.
3. Coat the fan shaft and sheaves with grease or other protective coating.
4. Seal the fan inlet and outlet with heavy-duty plywood.
5. Cover the entire fan with protective tarps.

Periodic attention during storage:

1. Rotate the fan shaft every 30 days to circulate bearing grease.
2. Purge the bearings of grease every 60 days. Rotate the shaft while purging grease.  
Do not use high-pressure pneumatic greasers.
3. Renew the protective coatings on the shaft, sheaves every 90 days.

Preparation for startup after long term storage:

1. Prior to startup purge the bearings with new grease and re-lubricate.
2. Remove any rust buildup from drive components and inspect drive belts for wear.
3. Manually rotate the fan impeller and check for any clearance issues.
4. Check all bearings and drive set screws. Check all hardware for tightness.
5. Follow storage guidelines in motor manual section.
6. Follow standard start up procedures.



A Division of VPC Fiberglass™ 2020



VPCFIBERGLASS.COM

ADMINISTRATIVE OFFICES

LOCKPORT MANUFACTURING

MEDINA MANUFACTURING

P: 585.735.9668  
F: 585.735.9965

2410 North Forest Road, Suite 301  
Getzville, NY 14068

75 Michigan Street, Suite 2  
Lockport, NY 14094

10478 Ridge Road  
Medina, NY 14103

# INSTALLATION, OPERATION & MAINTENANCE INSTRUCTIONS

## INSTALLATION

It is CFT's standard procedure to test run and balance all complete fan units before shipping. Your fan will be correctly aligned, lubricated, assembled, and ready for mounting on a proper foundation. The forces encountered during shipment, handling, and rigging can however disturb the factory settings. Before operating the fan be sure to follow the Start-Up procedure outlined in this manual. A good solid foundation equipped with anchoring devices (such as anchoring bolts) is required for proper installation with the least amount of vibration. Fans should be mounted to a flat, level, and rigid foundation. Roof curbs or equipment rails should be properly secured and sufficient to handle loading from fan. Fan must be set on its curb cap flatly or warping can occur. Level the foundation where necessary. Fan can be secured to the base using standard anchoring hardware. Wiring of all electrical components must be in accordance with applicable local codes, standards, and manufacturers' manual.

## PRE START-UP

The following procedure should be followed before starting the initial startup of after major servicing.

1. Make a visual inspection of the installation. Check for any loose items or debris that may be drawn into the fan inlet or dislodged by the fan discharge.
2. Confirm all fasteners are secure. All foundation bolts, bearing bolts, locking collars, set screws, and sheave mounting bolts must be properly tightened.
3. Check bearing alignment and lubrication.
4. Check V-belt drive alignment and belt tension.
5. Rotate the fan wheel by hand to check that it turns freely.
6. Confirm all electrical connections are correct.

## INITIAL START-UP

After satisfying the considerations listed in the previous section follow this procedure for initial startup.

1. "Bump" the motor to determine proper rotation of the propeller is achieved.
2. Fully energize the fan and allow it to achieve full speed. This is a good time to check startup and running amps.
3. Observe the fan and motor as the fan runs at operating speed. Unusual vibration or extreme motor or bearing heat should be investigated immediately.
4. Check the fan after it has been run for approximately (8) hours. Stop the fan and re-check all alignments, inspect the bearings and motor, check tightness of all hardware, and tension of belts.



A Division of VPC Fiberglass™ 2020

VPCFIBERGLASS.COM

P: 585.735.9668  
F: 585.735.9965

ADMINISTRATIVE OFFICES

2410 North Forest Road, Suite 301  
Getzville, NY 14068

LOCKPORT MANUFACTURING

75 Michigan Street, Suite 2  
Lockport, NY 14094



MEDINA MANUFACTURING

10478 Ridge Road  
Medina, NY 14103

# INSTALLATION, OPERATION & MAINTENANCE INSTRUCTIONS

## MAINTENANCE

To ensure trouble-free operation and long life, a regular schedule of preventative maintenance must be followed. Frequency of inspection and lubrication depend upon the operating conditions and the amount of time that the fan is used. We recommend daily observation after the fan is first put into service to determine the proper inspection and lubrication requirements.

Periodic inspections should include the following items:

1. Check for obstructions in the inlet and outlet of the fan.
2. V-belt drives- check for belt wear, alignment of sheaves, and belt tension.
3. Wheel- Inspect the blades for dust or dirt accumulation. Clean when necessary.
4. Hardware- Check that all hardware (foundation bolts, setscrews, fan hardware) is properly tightened.
5. Shaft- Check shaft for excessive wear.
6. Bearings- Check bearings for abnormal wear or excessive noise. Grease as required.
7. Motors- Check motors and grease motor bearings as required.

For detailed motor, bearing, and v-belt drive information see the appropriate insert.

Replacement parts can be ordered through your local sales representative or by contacting the CFT factory. The fan serial number will be required to order replacement parts.

Recommended spare parts:

1. Spare set of v-belts
2. Spare set of bearings (qty 2)
3. Shaft seal gaskets

For fans in critical locations, the following is also recommended:

1. Spare wheel
2. Spare motor



A Division of VPC Fiberglass™ 2020

VPCFIBERGLASS.COM

P: 585.735.9668  
F: 585.735.9965

ADMINISTRATIVE OFFICES

2410 North Forest Road, Suite 301  
Getzville, NY 14068

LOCKPORT MANUFACTURING

75 Michigan Street, Suite 2  
Lockport, NY 14094



MEDINA MANUFACTURING

10478 Ridge Road  
Medina, NY 14103

# INSTALLATION, OPERATION & MAINTENANCE INSTRUCTIONS

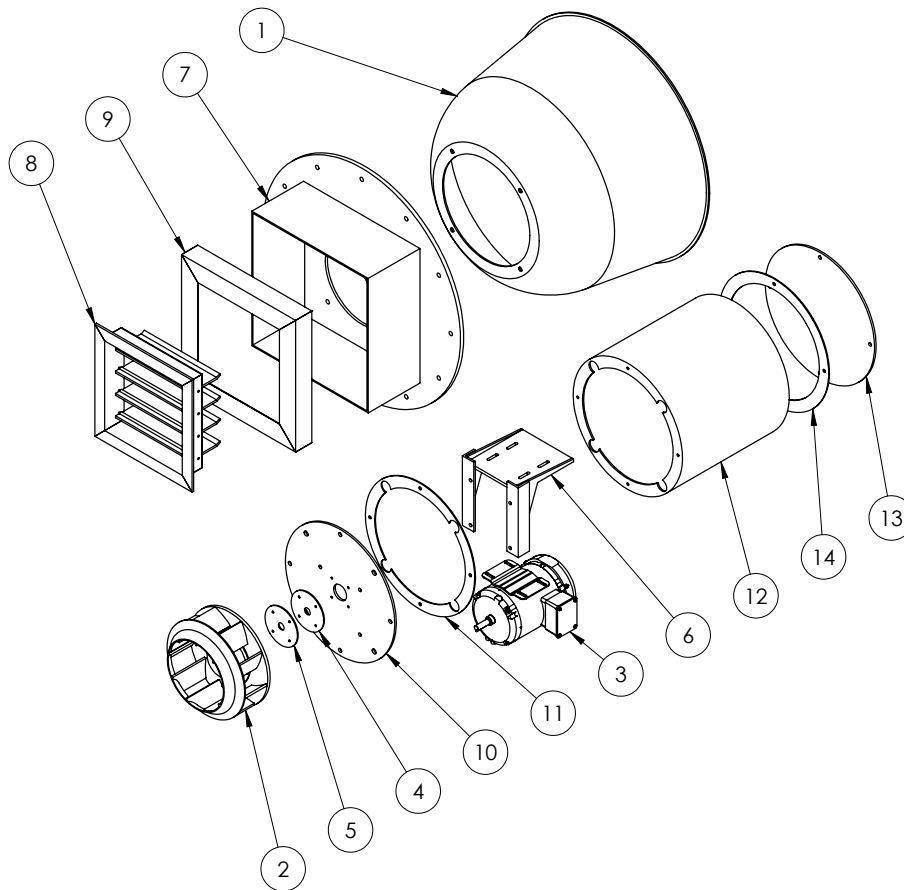

ITEM NO.	DESCRIPTION
1	HOUSING
2	WHEEL
3	MOTOR
4	SHAFT SEAL
5	SHAFT SEAL PLATE
6	MOTOR BASE
7	INLET WALL MOUNT
8	INLET DAMPER
9	DAMPER BRACKET
10	LOWER MOTOR PLATE
11	LOWER MOTOR PLATE GASKET
12	MOTOR COVER
13	UPPER MOTOR PLATE
14	UPPER MOTOR PLATE



A Division of VPC Fiberglass™ 2020

VPCFIBERGLASS.COM

P: 585.735.9668  
F: 585.735.9965

ADMINISTRATIVE OFFICES

2410 North Forest Road, Suite 301  
Getzville, NY 14068

LOCKPORT MANUFACTURING

75 Michigan Street, Suite 2  
Lockport, NY 14094



MEDINA MANUFACTURING

10478 Ridge Road  
Medina, NY 14103

# INSTALLATION, OPERATION & MAINTENANCE INSTRUCTIONS

## **SECTION A:** V-BELT DRIVE INFORMATION



A Division of VPC Fiberglass™ 2020

VPCFIBERGLASS.COM

P: 585.735.9668  
F: 585.735.9965

ADMINISTRATIVE OFFICES

2410 North Forest Road, Suite 301  
Getzville, NY 14068

LOCKPORT MANUFACTURING

75 Michigan Street, Suite 2  
Lockport, NY 14094



MEDINA MANUFACTURING

10478 Ridge Road  
Medina, NY 14103

# INSTALLATION, OPERATION & MAINTENANCE INSTRUCTIONS

## **SECTION B:** BEARING INFORMATION



A Division of VPC Fiberglass™ 2020

VPCFIBERGLASS.COM

P: 585.735.9668  
F: 585.735.9965

ADMINISTRATIVE OFFICES

2410 North Forest Road, Suite 301  
Getzville, NY 14068

LOCKPORT MANUFACTURING

75 Michigan Street, Suite 2  
Lockport, NY 14094



MEDINA MANUFACTURING

10478 Ridge Road  
Medina, NY 14103



# INSTALLATION, OPERATION & MAINTENANCE INSTRUCTIONS

## **SECTION C:** MOTOR INFORMATION



A Division of VPC Fiberglass™ 2020

VPCFIBERGLASS.COM

P: 585.735.9668  
F: 585.735.9965

ADMINISTRATIVE OFFICES

2410 North Forest Road, Suite 301  
Getzville, NY 14068

LOCKPORT MANUFACTURING

75 Michigan Street, Suite 2  
Lockport, NY 14094



MEDINA MANUFACTURING

10478 Ridge Road  
Medina, NY 14103

# INSTALLATION, OPERATION & MAINTENANCE INSTRUCTIONS

## WARRANTY INFORMATION

Composite Fan Technology warrants that the design, construction, and materials of our products will be free from defects in the materials and workmanship for a period not to exceed (18) months from the shipment date or (12) months from the date of installation, whichever occurs first. Our sole obligation under this warranty is limited to the repair or replacement, without charge, at the purchase order F.O.B. point, and defective parts supplied by Composite Fan Technology. Composite Fan Technology will not be responsible for damages, contingent liabilities, or consequential damages of any nature, resulting from any defect in our products, either in materials, design, construction, or arising from the use of such products. We do not guarantee against abrasion, corrosion, erosion, or accumulation of material on the fan rotor (buildup).

The above stated Warranty is given expressly in lieu of all other warranties expressed or implied, including warranties of merchantability and fitness for a particular purpose, and constitutes the only warranty made by the seller.

Composite Fan Technology shall not be liable for any injury to persons or property resulting from improper installation, operation, misapplication, modification, repair, or maintenance (including lubrication) of equipment. Warranty does not cover any product which, in the determination of Composite Fan Technology, has received neglect or was misused.

All warranty claims must be submitted to Composite Fan Technology within (10) days of discovery of the defect within the warranty period, or shall be deemed waived. Do not attempt to make any repairs on the fan equipment during the warranty period without prior written authorization of Composite Fan Technology or its representatives, otherwise warranty is voided.



A Division of VPC Fiberglass™ 2020



VPCFIBERGLASS.COM

ADMINISTRATIVE OFFICES

LOCKPORT MANUFACTURING

MEDINA MANUFACTURING

P: 585.735.9668  
F: 585.735.9965

2410 North Forest Road, Suite 301  
Getzville, NY 14068

75 Michigan Street, Suite 2  
Lockport, NY 14094

10478 Ridge Road  
Medina, NY 14103